

Overview:

The Generic Framing Protocol (GFP) IP core implements the ITU-T G.7041 communication standard. The GFP IP core operates in PDU oriented adaptation mode, referred to as Frame Mapped GFP (GFP – F) mode. The IP core consists of a transmission and a reception unit that enable the transmission and reception of data to or from a SONET/SDH network. The GFP-F Encapsulation core receives data from the client network over an Ethernet interface, encapsulates the data according to GFP protocol, and transmits the GFP encapsulated data frame. The GFP-F Decapsulation core receives the GFP encapsulated data frames from higher network layer, de-maps the GFP frames to extract client network data to be transmitted over an Ethernet interface.

Features:

- Implements the ITU-T G.7041 GFP Specification
- Frame mapped GFP (GFP – F) support
- Supports all frame mapped protocols defined in the ITU-T GFP specification like Ethernet, PPP, MPLS, IP and DVB-ASI.
- Supports Null extension header.
- Client data frames support
- 32-bit OPB Interface for data transfer
- Single bit error correction for Type Header and Core Header using CRC 16

Key Benefits:

- Customizable HDL design
- High data rate capabilities
- RTL source code available for easy integration and implementation.

Block diagram:

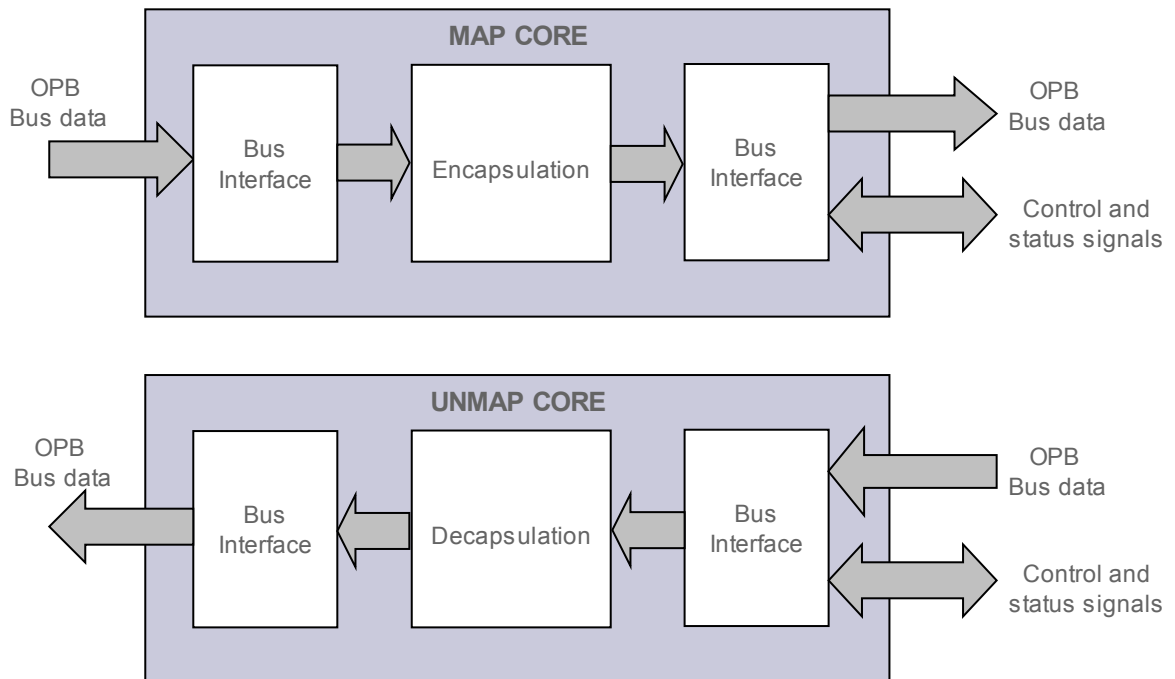

Figure: GFP Core block diagram

Applications:

- Transport of IP/Ethernet Protocols over SONET/SDH/PDH
- Transport of LAN/SAN over SONET/SDH/PDH

Application Note – Ethernet to PDH mapper:

Ethernet–PDH mapper provides GFP–F mapping of Ethernet traffic into PDH signals. Ethernet– PDH is a protocol converter that transports Ethernet services over existing PDH signal formats.

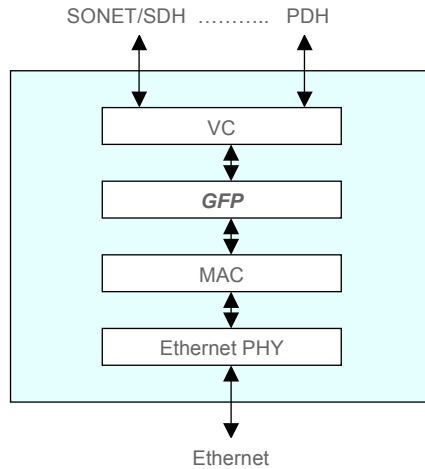

Deliverables:

- Core options
 - RTL design in VHDL
 - Technology specific netlist
- Test bench
- Documentation

Support and warranty:

The core is code tested, extensively simulated and thoroughly verified on hardware board. The core is warranted against defects and meets the technical specifications. In rarest case, if the core has some defects or do not comply with the specifications laid down, same will be rectified within a shortest possible time. Thirty (30) days of free technical support through telephone/e-mail/chat (voice and non-voice) is included. Additional maintenance support options available on request.

Customization:

Best efforts have been made to ensure that the core has most relevant features and can fit into wide range of applications. However, the customer may require some specific functions in the core. The core can be customized or modified on customers request to meet their requirement specifications.

Target Technologies:

- **FPGA:** Spartan 3, Virtex, Virtex 2/Pro, Virtex 4, Virtex 5
- ASIC standard cell

Device utilization summary:

Target Device: Xilinx Spartan 3s1500fg456			
	Max. frequency (MHz)	No. of Slices used	No. of Block RAMs used
Encapsulation side	86	805	3
Decapsulation side	78	553	-



VXL Technologies Ltd.
 No. 9/1, 14th Floor, Birla Building, R.N.Mukherjee Road, Kolkata 700 001, India
 Tel.: +91 33 2213 3685 Fax: +91 33 2213 3686
 E-Mail: sales@vxldesign.com Website: www.vxldesign.com